

LOCATION OF LAND

PARISH: PHILLIP ISLAND AT COWES
TOWNSHIP: —
SECTION: —
CROWN ALLOTMENT: 15 (PT), 16 (PT), 17(PT) & 18
CROWN PORTION: —

TITLE REFERENCE: VOL.10999 FOL.724
VOL.10827 FOL.774

LAST PLAN REFERENCE: LOT A ON PS534627A

POSTAL ADDRESS: SEAGROVE WAY
(at time of subdivision) COWES 3922

M.G.A. CO-ORDINATES E 344 920 ZONE: 55
(of approx. centre of land in plan) N 5 741 550

COUNCIL CERTIFICATION AND ENDORSEMENT

COUNCIL NAME: BASS COAST SHIRE COUNCIL REF: —

- This plan is certified under section 6 of the Subdivision Act 1988.
- This plan is certified under section 11(7) of the Subdivision Act 1988.
Date of original certification under section 6 / /
- This is a statement of compliance issued under section 21 of the Subdivision Act 1988.

OPEN SPACE

(i) A requirement for public open space under section 18 of the Subdivision Act 1988 has/has not been made.
(ii) The requirement has been satisfied.
(iii) The requirement is to be satisfied in Stage.....

Council Delegate
Council Seal

Date / /

Re-certified under section 11(7) of the Subdivision Act 1988.

Council Delegate
Council Seal

Date / /

VESTING OF ROADS AND / OR RESERVES	
IDENTIFIER	COUNCIL/BODY/PERSON
RESERVE No.1 ROAD R1	BASS COAST SHIRE COUNCIL BASS COAST SHIRE COUNCIL

NOTATIONS

STAGING THIS IS NOT A STAGED SUBDIVISION
PLANNING PERMIT No 040248

DEPTH LIMITATION DOES NOT APPLY.

LOT NUMBERS 1 TO 91, 106 & 121 TO 158 (ALL INCLUSIVE) HAVE BEEN OMITTED FROM THIS PLAN.

FOR RESTRICTIONS AFFECTING LOTS ON THIS PLAN SEE THE CREATIONS OF RESTRICTION ON SHEETS 6 & 7.

THE LAND BEING SUBDIVIDED IS ENCLOSED WITHIN THICK CONTINUOUS LINES.

SURVEY THIS PLAN IS BASED ON SURVEY IN AP123462W.

THIS SURVEY HAS BEEN CONNECTED TO PERMANENT MARKS No.(s) —
IN PROCLAIMED SURVEY AREA No. —

EASEMENT INFORMATION

LEGEND: E - ENCUMBERING EASEMENT OR CONDITION IN CROWN GRANT IN THE NATURE OF AN EASEMENT
A - APPURTENANT EASEMENT R - ENCUMBERING EASEMENT (ROAD)

SUBJECT LAND	PURPOSE	WIDTH (METRES)	ORIGIN	LAND BENEFITED/IN FAVOUR OF
E-1	DRAINAGE	SEE DIAG.	PS524867K	BASS COAST SHIRE COUNCIL
E-1	SEWERAGE	SEE DIAG.	PS524867K	WESTERNPORT REGION WATER AUTHORITY
E-2	DRAINAGE	SEE DIAG.	PS534627A	BASS COAST SHIRE COUNCIL
E-2 & E-3	SEWERAGE	SEE DIAG.	PS534627A	WESTERNPORT REGION WATER AUTHORITY
E-4	DRAINAGE	SEE DIAG.	THIS PLAN	BASS COAST SHIRE COUNCIL
E-4 & E-5	SEWERAGE	SEE DIAG.	THIS PLAN	WESTERNPORT REGION WATER CORPORATION

LR USE ONLY

STATEMENT OF COMPLIANCE/
EXEMPTION STATEMENT

RECEIVED

DATE / /

LR USE ONLY

PLAN REGISTERED
TIME
DATE / /

.....
Assistant Registrar of Titles

SHEET 1 OF 7 SHEETS

BEVERIDGE WILLIAMS & CO. PTY.LTD.
ACN 006 197 235 ABN 44 622 029 694
SURVEYORS . ENGINEERS . PLANNERS
ENVIRONMENTAL CONSULTANTS
PO BOX 2205 CAULFIELD JUNCTION 3161 95284444
PO BOX 1465 BALLARAT MAIL CENTRE 3354 53313877
PO BOX 161 LEONGATHA 3953 56622630
PO BOX 129 WONTHAGGI 3995 56721505
PO BOX 1916 TRARALGON 3844 51760374

LICENSED SURVEYOR LINCOLN SCOTT MORRIS
(PRINT)

SIGNATURE DATE: 17/11/2008

REF. L4015/3 VERSION 11

DATE / /

COUNCIL DELEGATE SIGNATURE

ORIGINAL SHEET SIZE A3

PLAN OF SUBDIVISION

Stage No. /

Plan Number

PS603109R

CURRAWONG CLOSE

KEY DIAGRAM

FOR LOTS 92 TO 105, 107 TO 120
(ALL INCLUSIVE), LOT 159, ROAD R1 &
EASEMENTS SEE SHEETS 3, 4 & 5.

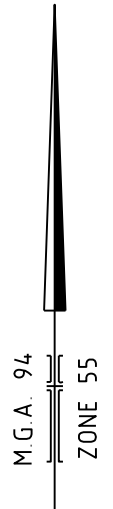
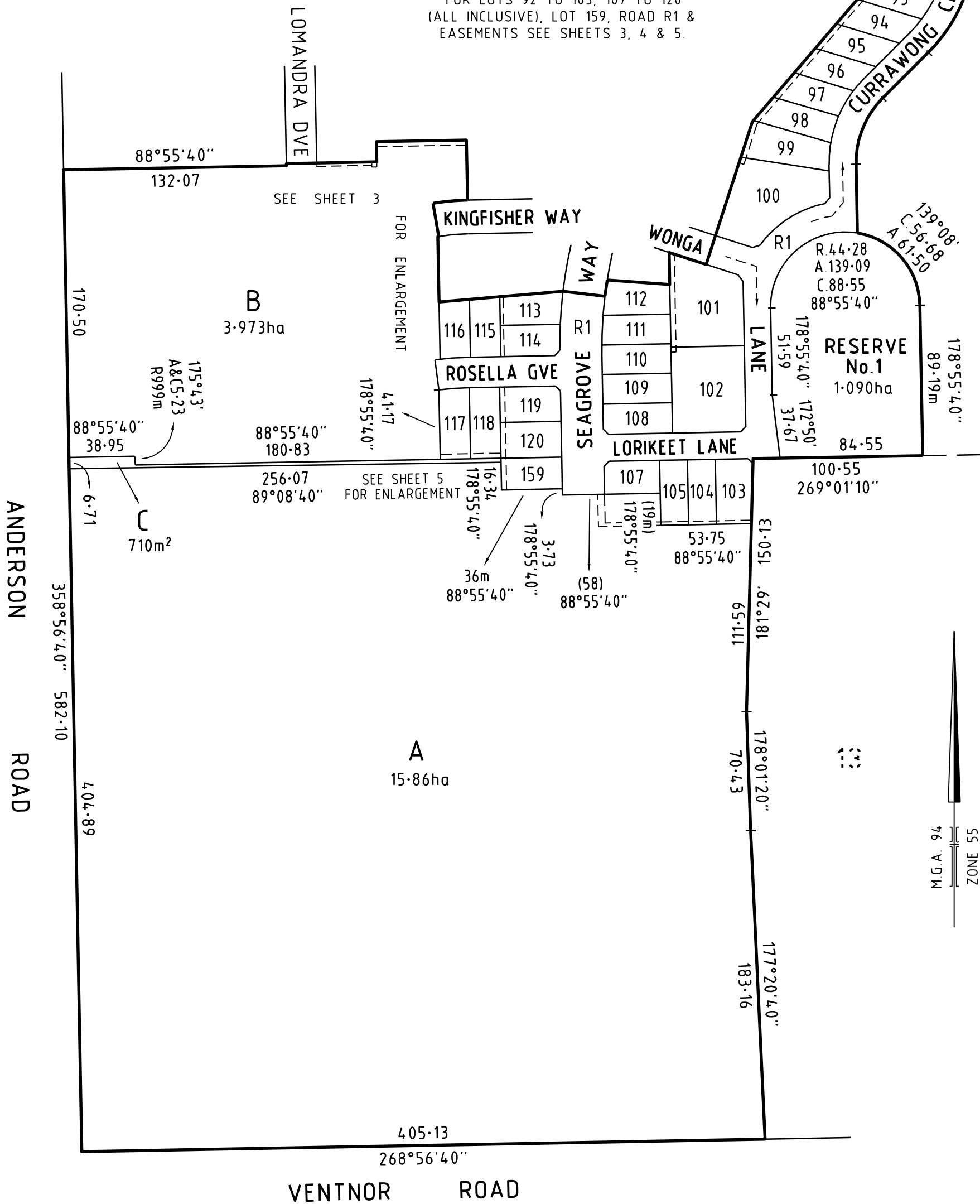

BEVERIDGE WILLIAMS & CO. PTY.LTD.
ACN 006 197 235 ABN 44 622 029 694
SURVEYORS . ENGINEERS . PLANNERS
ENVIRONMENTAL CONSULTANTS
PO BOX 2205 CAULFIELD JUNCTION 3161 95284444
PO BOX 1465 BALLARAT MAIL CENTRE 3354 53313877
PO BOX 161 LEONGATHA 3953 56622630
PO BOX 129 WONTHAGGI 3995 56721505
PO BOX 1916 TRARALGON 3844 51760374

Sheet 2 of 7 Sheets

ORIGINAL
SCALE 1.2500
SHEET SIZE A3

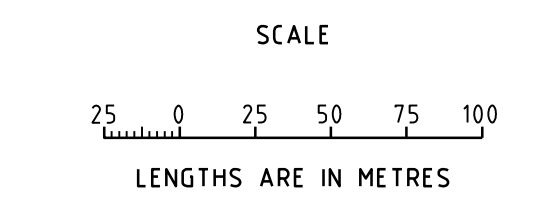

LICENSED SURVEYOR (PRINT) LINCON SCOTT MORRIS
SIGNATURE _____ DATE 17/11/2008
REF. **L4015/3** VERSION 11

DATE / /
COUNCIL DELEGATE SIGNATURE
Original sheet size A3

PLAN OF SUBDIVISION

Stage No.

Plan Number

PS603109R

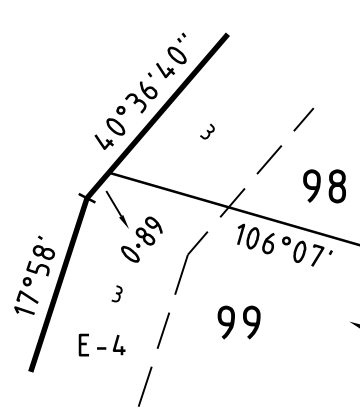
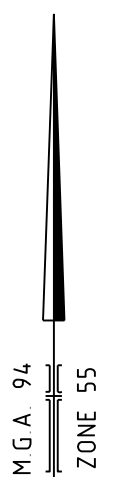
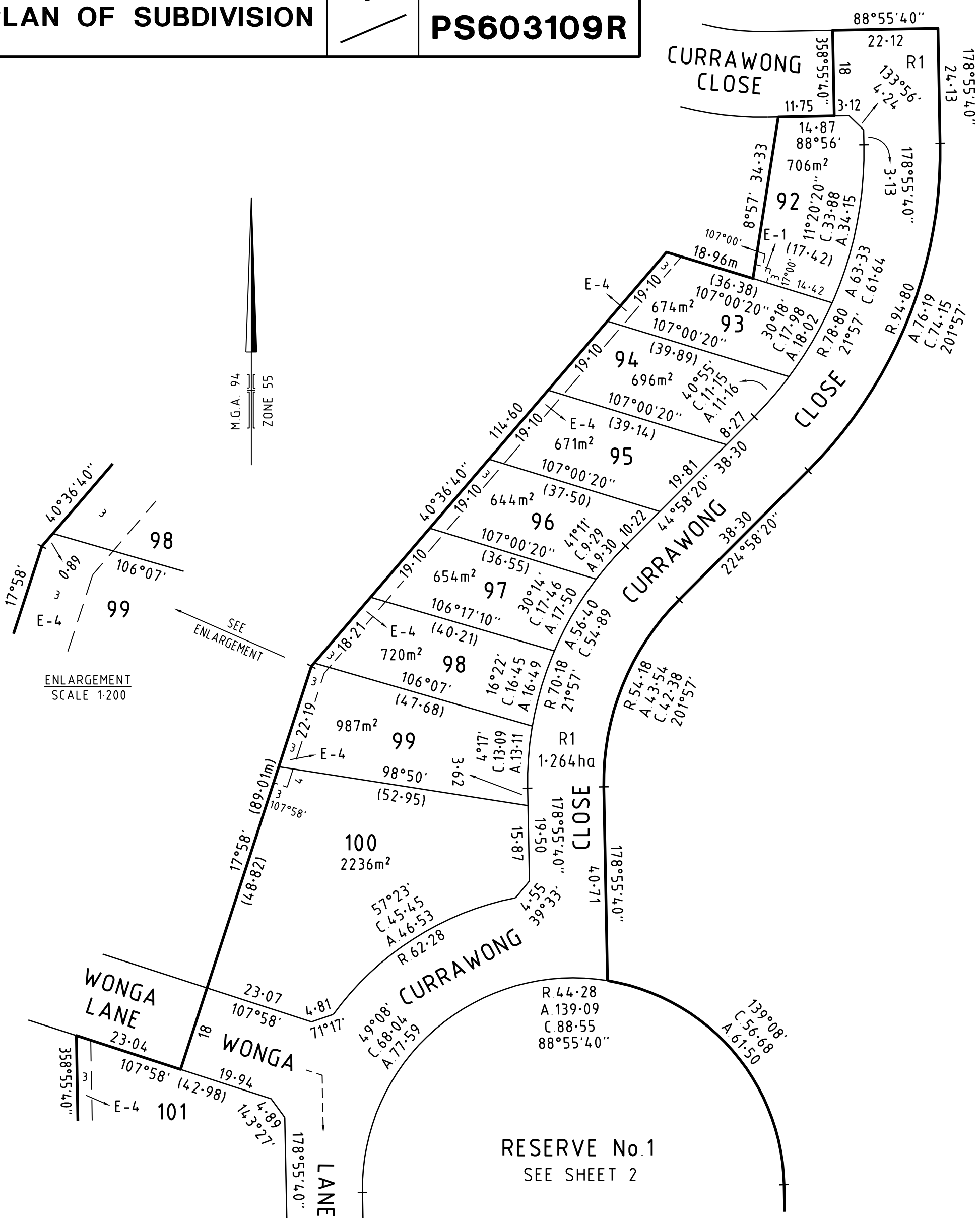

ENLARGEMENT
SCALE 1:200

SEE
ENLARGEMENT

CONTINUED SHEET 5

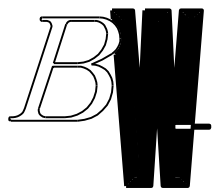

BEVERIDGE WILLIAMS & CO. PTY.LTD.
 ACN 006 197 235 ABN 44 622 029 694
SURVEYORS . ENGINEERS . PLANNERS
ENVIRONMENTAL CONSULTANTS
 PO BOX 2205 CAULFIELD JUNCTION 3161 95284444
 PO BOX 1465 BALLARAT MAIL CENTRE 3354 53313877
 PO BOX 161 LEONGATHA 3953 56622630
 PO BOX 129 WONTHAGGI 3995 56721505
 PO BOX 1916 TRARALGON 3844 51760374

ORIGINAL
SCALE 1800
SHEET SIZE A3

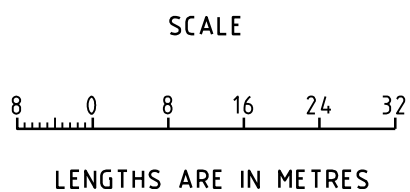

LICENSED SURVEYOR (PRINT) LINCOLN SCOTT MORRIS
 SIGNATURE _____ DATE 17/11/2008
 REF. L4015/3 VERSION 11

Sheet 4 of 7 Sheets
 DATE / /
 COUNCIL DELEGATE SIGNATURE
 Original sheet size A3

PLAN OF SUBDIVISION

Stage No. /

Plan Number

PS603109R

CONTINUED SHEET 4

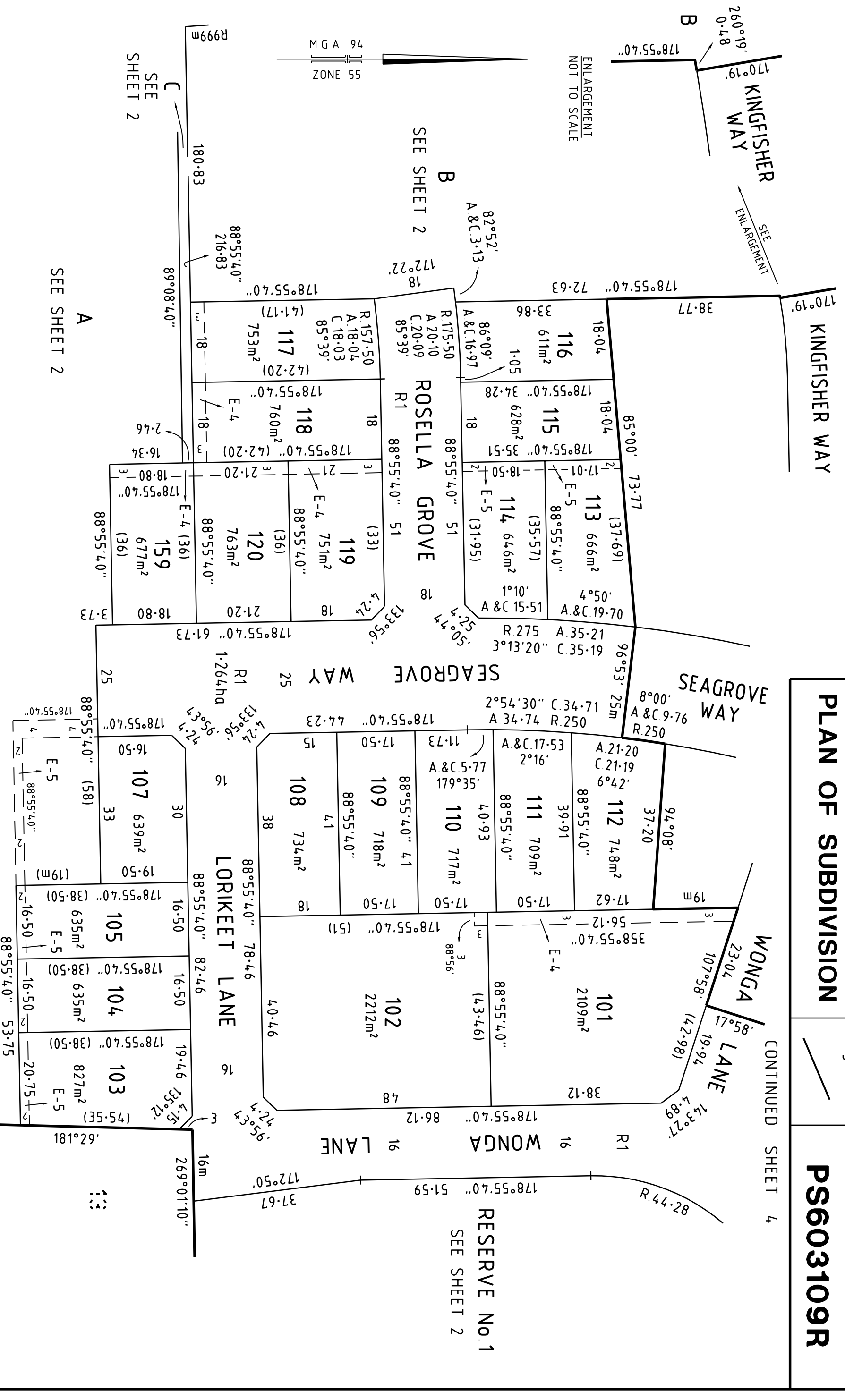

BEVERIDGE WILLIAMS & CO. PTY.LTD.
 ACN 006 197 235 ABN 44 622 029 694
SURVEYORS · ENGINEERS · PLANNERS
ENVIRONMENTAL CONSULTANTS
 PO BOX 2205 CAULFIELD JUNCTION 3161 95284444
 PO BOX 1465 BALLARAT MAIL CENTRE 3354 53318877
 PO BOX 161 LEONGATHA 3953 56622630
 PO BOX 129 WINTHAGGI 3995 56721505
 PO BOX 1916 TRARALGON 3844 51760374

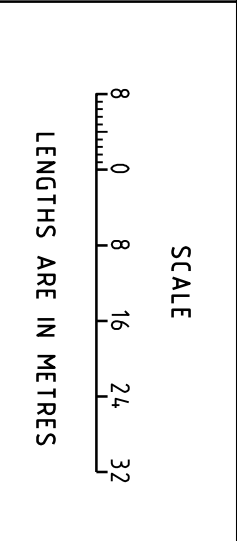

ORIGINAL SCALE 1800 SHEET SIZE A3

LICENSED SURVEYOR (PRINT) LINCOLN SCOTT MORRIS
 SIGNATURE _____ DATE 17/11/2008
 REF **L4015/3** VERSION 11

SHEET 5 OF 7 SHEETS
 DATE / /
 COUNCIL DELEGATE SIGNATURE _____

PLAN OF SUBDIVISION

Stage No.

Plan Number

PS603109R

CREATION OF RESTRICTION 'A'

UPON REGISTRATION OF THIS PLAN THE FOLLOWING RESTRICTION IS CREATED

LAND TO BENEFIT : LOTS ON THIS PLAN.
LAND TO BE BURDENED : LOT 103 ON THIS PLAN.

DESCRIPTION OF RESTRICTION

THE REGISTERED PROPRIETOR OR PROPRIETORS OF LOT 103 SHALL NOT CONSTRUCT ANY BUILDING OR STRUCTURE OTHER THAN A FENCE WITHIN THE AREA SHOWN CROSS HATCHED ON THE DIAGRAM.

VARIATION

VARIATION OF THIS REQUIREMENT WILL REQUIRE PLANNING APPROVAL FROM THE RESPONSIBLE AUTHORITY.

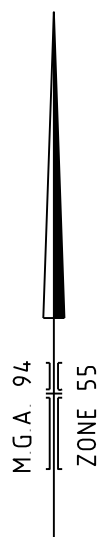

LORIKEET LANE

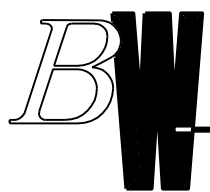
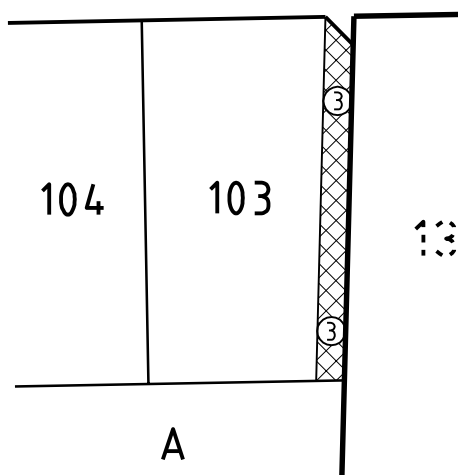

BEVERIDGE WILLIAMS & CO. PTY.LTD.
ACN 006 197 235 ABN 44 622 029 694
SURVEYORS . ENGINEERS . PLANNERS
ENVIRONMENTAL CONSULTANTS
PO BOX 2205 CAULFIELD JUNCTION 3161 95284444
PO BOX 1465 BALLARAT MAIL CENTRE 3354 53313877
PO BOX 161 LEONGATHA 3953 56622630
PO BOX 129 WONTHAGGI 3995 56721505
PO BOX 1916 TRARALGON 3844 51760374

Sheet 6 of 7 Sheets

ORIGINAL
SCALE SHEET SIZE
1:800 A3

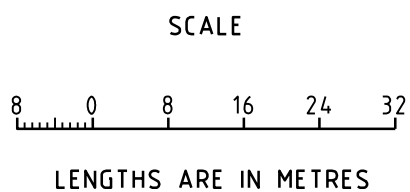

LICENSED SURVEYOR (PRINT) LINCOLN SCOTT MORRIS
SIGNATURE _____ DATE 17/11/2008
REF. L4015/3 VERSION 11

DATE / /
COUNCIL DELEGATE SIGNATURE
Original sheet size A3

PLAN OF SUBDIVISION

Stage No. /

Plan Number

PS603109R

CREATION OF RESTRICTION 'B'

UPON REGISTRATION OF THIS PLAN THE FOLLOWING RESTRICTION IS CREATED

LAND TO BENEFIT : LOTS ON THIS PLAN.

LAND TO BE BURDENED : LOTS 93 TO 100 (BOTH INCLUSIVE) AND LOT 159 ON THIS PLAN.

DESCRIPTION OF RESTRICTION

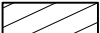
THE REGISTERED PROPRIETOR OR PROPRIETORS OF LOTS 93 TO 100 (BOTH INCLUSIVE) AND LOT 159 ON THIS PLAN SHALL NOT CONSTRUCT ANY DWELLING OR GARAGE EXCEPT WITHIN THE BUILDING ENVELOPE SHOWN THUS 

LEGEND

REGULATION 406 OF THE BUILDING REGULATIONS 2006 EXEMPTS BUILDINGS FROM THE NEED TO COMPLY WITH ANY REGULATION IN PART 4 OF THE BUILDING REGULATIONS 2006 IF THE DESIGN OF THE BUILDING COMPLIES WITH AN APPROVED BUILDING ENVELOPE THAT DEALS WITH THAT PARTICULAR REGULATION.

FOR THE PURPOSE OF REGULATION 406 OF THE BUILDING REGULATIONS 2006, THE BUILDING ENVELOPES ON THIS PLAN ONLY REGULATE SITING MATTERS DEALT WITH BY REGULATIONS 408 & 409 OF THE BUILDING REGULATIONS 2006.

VARIATION

VARIATION OF THIS REQUIREMENT WILL REQUIRE PLANNING APPROVAL FROM THE RESPONSIBLE AUTHORITY.

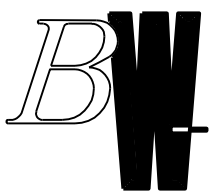
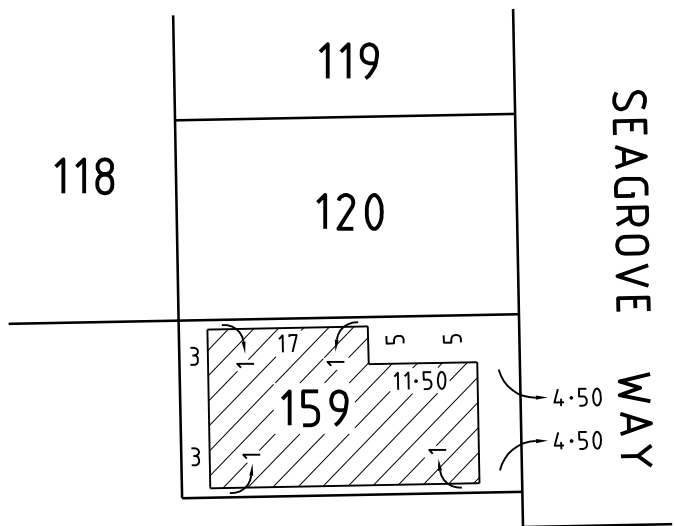
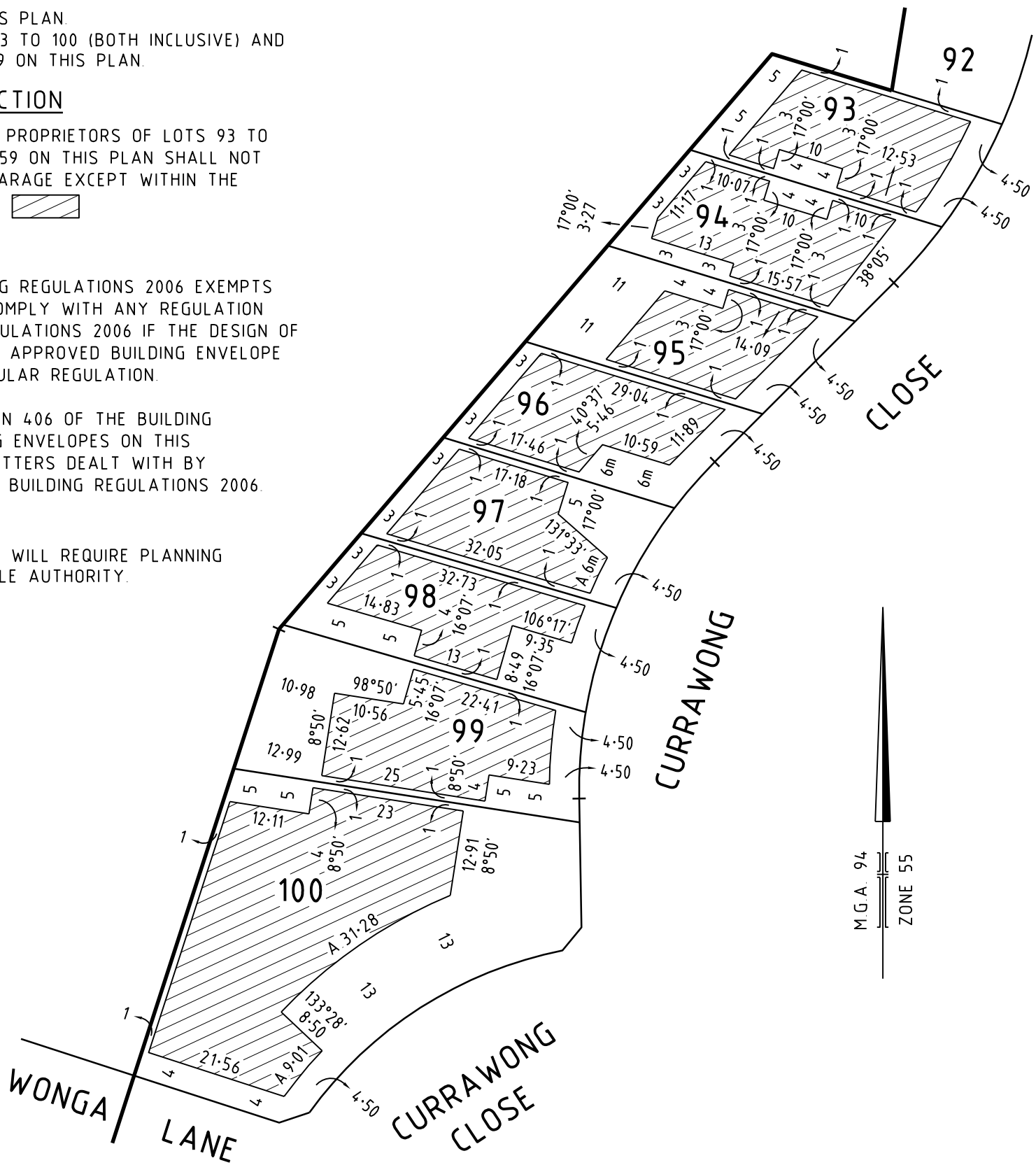

BEVERIDGE WILLIAMS & CO. PTY.LTD.
 ACN 006 197 235 ABN 44 622 029 694
SURVEYORS . ENGINEERS . PLANNERS
ENVIRONMENTAL CONSULTANTS
 PO BOX 2205 CAULFIELD JUNCTION 3161 95284444
 PO BOX 1465 BALLARAT MAIL CENTRE 3354 53313877
 PO BOX 161 LEONGATHA 3953 56622630
 PO BOX 129 WONTHAGGI 3995 56721505
 PO BOX 1916 TRARALGON 3844 51760374

ORIGINAL	
SCALE	SHEET SIZE
1:800	A3

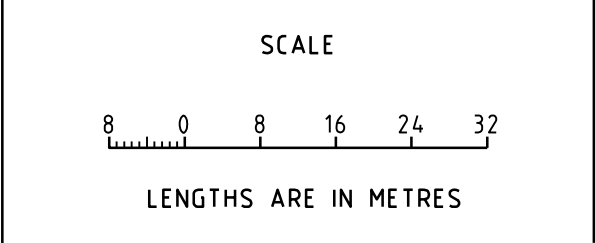

LICENSED SURVEYOR (PRINT) LINCOLN SCOTT MORRIS

SIGNATURE DATE 17/11/2008

REF. **L4015/3** VERSION 11

Sheet 7 of 7 Sheets

DATE / /

COUNCIL DELEGATE SIGNATURE

Original sheet size A3